



EKL 21908

for INTEL[®] Socket 775, 115X, 1200

Optimum cooling performance for INTEL[®] processors

Product description

The EKL 21908 consists of an extrusion profile and dissipates the heat from your processor ideally and reliably. Thanks to its compact height of just 60 mm, this cooler is ideal for all compact PC systems, workstations or even normal office PCs. The built-in fan has a 4-pin connection and can therefore be controlled manually via the mainboard. This enables an adjustable speed range of 900-1800 rpm. Thanks to the existing PWM signal, the fan operates depending on the utilisation of the CPU.

Main features

- ✓ Simple Intel ref. push-pin mounting
- ✓ Dual mounting system for Intel Socket 775 / 115X
- ✓ Cost-optimised aluminium design
- ✓ High-performance thermal paste
- ✓ Quiet PWM-controlled 92 mm fan

Advice & ordering:

 +49 (0)7561 9837-0

 info@ekl-ag.de



* Thermal and mechanical compatibility may vary depending on the system used
** According to manufacturer specifications

www.ekl-ag.de

EKL 21908 Technical data



Cooler properties

Retail article number	EKL 21908
Power loss	95W TDP
Material	Aluminium
Weight	386 g
Packaging unit	18
suitable for	INTEL® Socket 775 INTEL® Socket 115X INTEL® Socket 1200

Fan properties

Speed min.	900 U/min
Speed max.	1800 U/min
Warehouse	Hydraulic bearing
Operating voltage	12 VDC
Volume flow	62.63 m ³ /h
Noise level min.	17.8 dB(A)
Noise level max.	14.3 dB(A)
Service life L10	40000 h by 40 °C



* Thermal and mechanical compatibility may vary depending on the system used
** According to manufacturer specifications

www.ekl-ag.de

EKL[®]
electronics cooling

EKL 21908 Dimensions

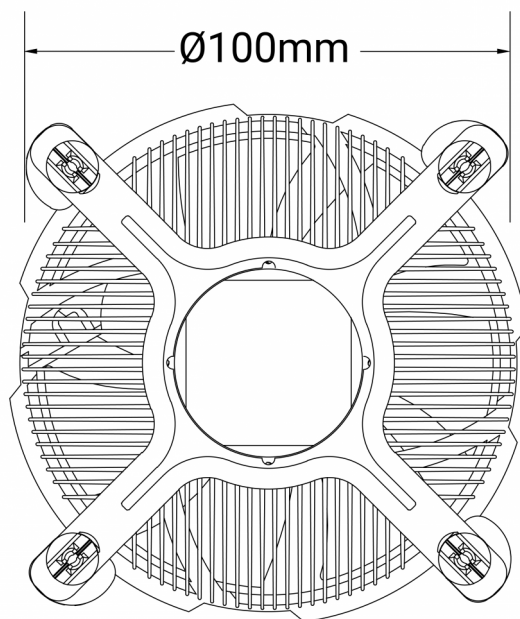
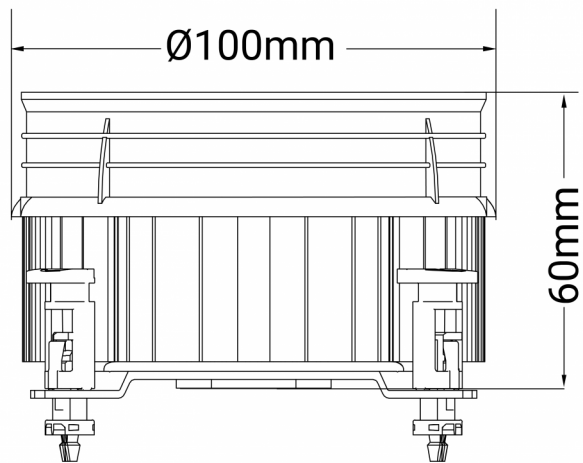

* Thermal and mechanical compatibility may vary depending on the system used
** According to manufacturer specifications

www.ekl-ag.de

EKL[®]
electronics cooling