

## EKL 22207

35/65W TDP Premium Cooler for  
INTEL<sup>®</sup> Socket LGA 17XX / 1851

### Optimum cooling performance for Intel<sup>®</sup> processors

#### Product description

With an extremely low height of just 30mm, the EKL 22207 is ideal for compact PC systems in the small form factor range. Especially in this size range, it is often difficult to procure a powerful and quiet CPU cooler. The EKL 22207 overcomes both challenges with flying colours. The combination of an aluminium profile, high-performance thermal compound and a low-vibration PWM-controlled fan guarantees quiet and extremely effective heat dissipation.

35W according to Intel specifications. 65W at intake temperature up to 40°C.

#### Main features

- ✓ Powerful top-flow design
- ✓ High-performance thermal paste
- ✓ Quiet and low-vibration 80 mm PWM fan
- ✓ Simple and tool-free push-pin assembly for Intel<sup>®</sup> socket LGA 17XX

Advice & ordering:

 +49 (0)7561 9837-0

 info@ekl-ag.de



\* Thermal and mechanical compatibility may vary depending on the system used  
\*\* According to manufacturer specifications

www.ekl-ag.de

# EKL 22207 Technical data

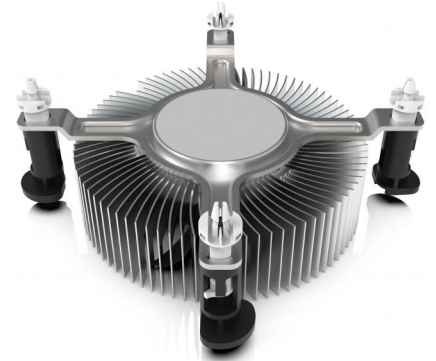
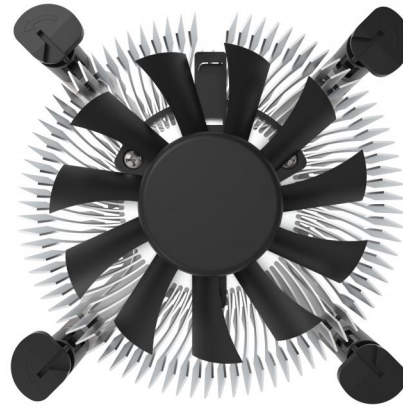

## Cooler properties

Retail article number	22210021007
EAN Retail	4250280331837
Power loss	35/65 <sup>1</sup> W TDP
Material	Aluminium
Weight	152 g
Packaging unit	32
suitable for	INTEL® Socket LGA 17XX / 1851

## Fan properties

Width	90 mm
Length	90 mm
Height	30 mm
Speed min.	500 U/min
Speed max.	2700 U/min
Warehouse	Ball/slide bearing
Operating voltage	12 VDC
Volume flow	52.5 m <sup>3</sup> /h
Noise level min.	21 dB(A)
Noise level max.	35 dB(A)
Service life L10	40000 h by 40 °C



\* Thermal and mechanical compatibility may vary depending on the system used  
\*\* According to manufacturer specifications

[www.ekl-ag.de](http://www.ekl-ag.de)

**EKL**<sup>®</sup>  
electronics cooling

# EKL 22207 Dimensions

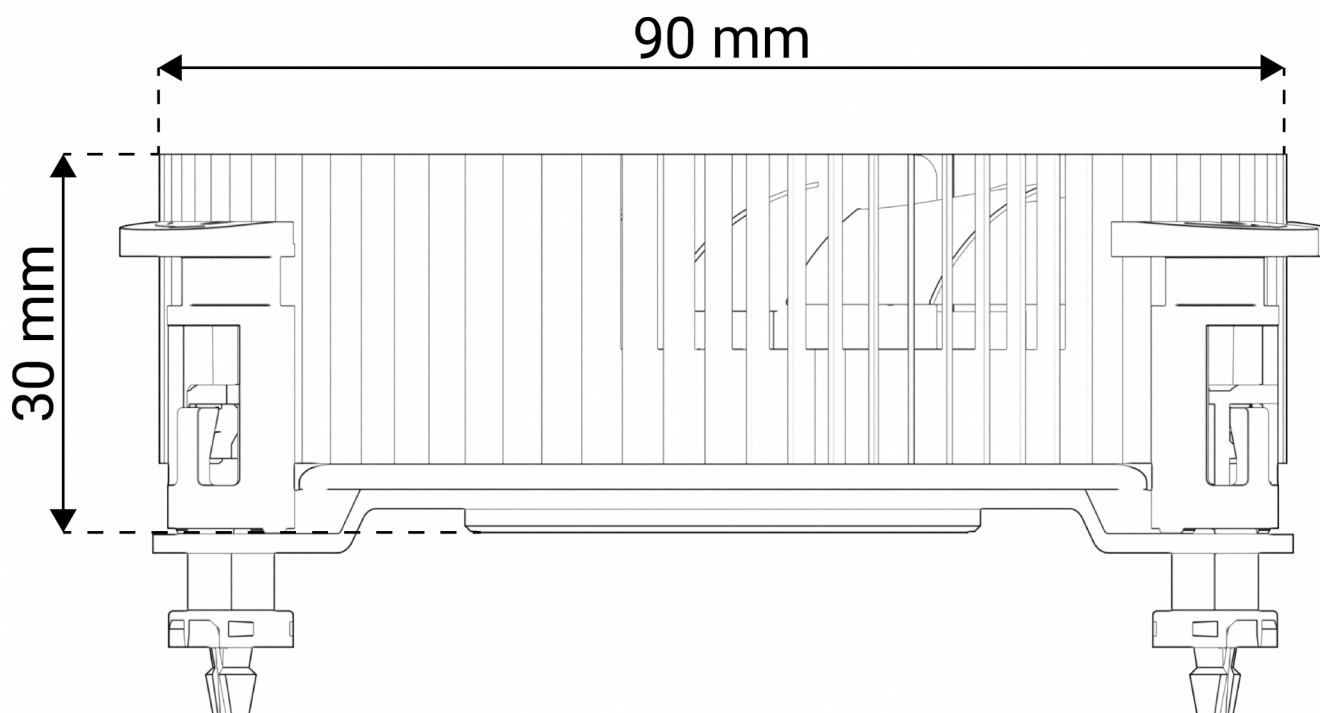

\* Thermal and mechanical compatibility may vary depending on the system used  
\*\* According to manufacturer specifications

[www.ekl-ag.de](http://www.ekl-ag.de)