



EKL 22226

35/65W TDP Premium Cooler for
INTEL[®] Socket LGA 1700/1851

Optimum cooling performance for INTEL[®] processors

Product description

The EKL 22226 consists of an extrusion profile and dissipates the heat of your processor ideally and reliably. With a compact height of just 42 mm, this cooler is ideal for all compact PC systems, workstations or even normal office PCs. The built-in fan has a 4-pin connection and can therefore be controlled manually via the mainboard. This enables an adjustable speed range of 500 - 2,200 rpm. Thanks to the existing PWM signal, the fan operates depending on the utilisation of the CPU.

Main features

- ✓ Powerful top-flow design
- ✓ Secure and stable screw mounting with included backplate for Intel[®] socket LGA 17XX
- ✓ High-performance thermal paste
- ✓ Quiet and low-vibration 92 mm PWM fan

Advice & ordering:

 +49 (0)7561 9837-0

 info@ekl-ag.de



* Thermal and mechanical compatibility may vary depending on the system used
** According to manufacturer specifications

www.ekl-ag.de

EKL 22226 Technical data

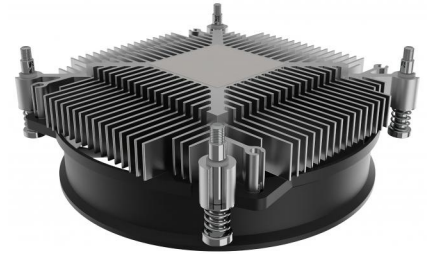
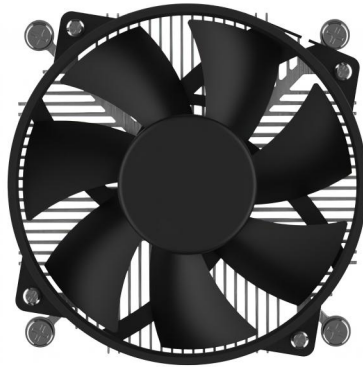

Cooler properties

Retail article number	22210021026
EAN Retail	4250280354898
Power loss	35/65 ¹ W TDP
Material	Aluminium
Weight	265 g
Packaging unit	30 Cooler / box
suitable for	INTEL® Socket LGA 17XX / 1851

Fan properties

Width	95 mm
Length	95 mm
Height	42 mm
Speed min.	500 U/min
Speed max.	1800 U/min
Warehouse	Hydraulic bearing
Operating voltage	12 VDC
Volume flow	77.81 m ³ /h
Noise level min.	12 dB(A)
Noise level max.	25.7 dB(A)
Service life L10	20000 h by 40 °C



* Thermal and mechanical compatibility may vary depending on the system used
** According to manufacturer specifications

www.ekl-ag.de

EKL 22226 Dimensions

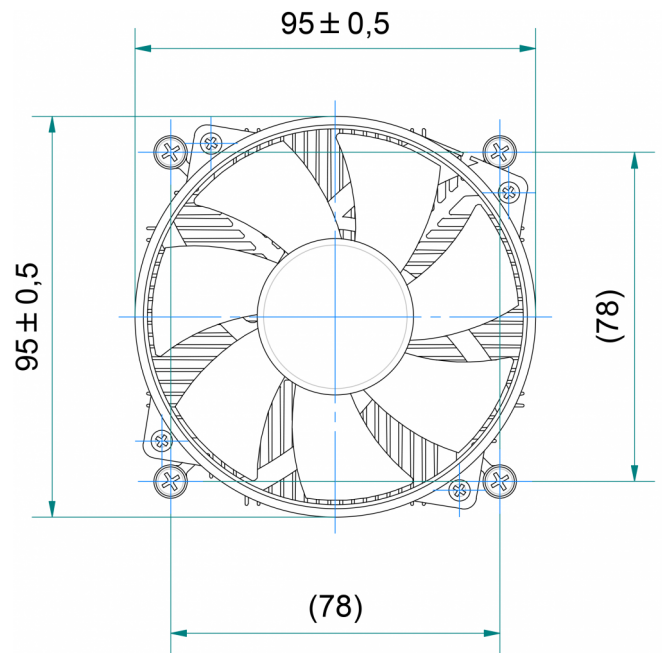
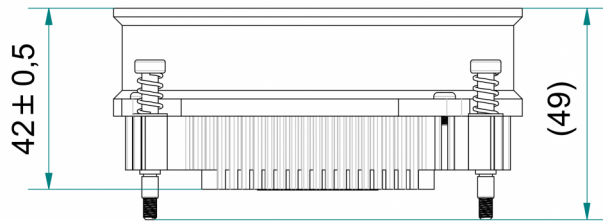

* Thermal and mechanical compatibility may vary depending on the system used
** According to manufacturer specifications

www.ekl-ag.de

EKL[®]
electronics cooling